

**1 or 2 Lamp  
T5, T5HO, or T8**

**APPLICATION**

- Highly efficient, highly flexible surface mounted luminaire with an upscale architectural appearance.
- Modern, countoured shape provides architectural detail and a “floating” visual effect without dominating the room.
- Excellent visual comfort, ideal for modern high-tech offices.
- Other applications include schools and retail environments.
- Many ballast/lamp systems are available, providing flexibility to tailor the luminaire to specific applications.
- Wide “batwing” distribution allows wider luminaire spacing and improves uniformity for more even lighting.
- High optical efficiency increases energy savings.
- Step dimming ballasts can be switched to less than 50% input power for energy savings to meet most energy codes while maintaining symmetrical illumination.
- Multiple shielding options create a wide variety of photometric variations and aesthetic effects.

**CONSTRUCTION/FINISH**

- Extruded aluminum external construction provides accurate, high quality fit and finish.
- Matte white external finish is standard, custom colors available.
- Approximate weight 35lbs.

**ELECTRICAL**

- UL listed for damp locations. Canadian certified optional.
- Standard size fluorescent emergency ballasts can be incorporated, UL listed for dry locations.
- Systems are available offering electrical system efficacy ratings up to 96 Lumens/Watt.

**ENCLOSURES**

- One-piece enclosure hinges down as an assembly for easy access to lamps and ballast from below.
- T-hinges provide secure retention of enclosure and eliminate non-captive parts to hold during servicing.
- Guide-post spring loaded latches allow easy opening and closing of the enclosure.
- Choice of shielding includes diffuse acrylic with or without overlay, white radial louver with overlay, round or linear perforated steel with overlay.

**CATALOG NUMBER**

<b>1</b>	<b>SAT</b>	<b>W</b>							
<b>WIDTH</b>	<b>FAMILY</b>	<b>DISTRIBUTION</b>	<b>NO. OF LAMPS</b>	<b>DIFFUSERS</b>	<b>BALLAST CONFIG.</b>	<b>OPTIONS</b>			
1 - 1'	SAT - Surface Attune	W - Wide (Batwing)	(not included) 1 2 (28wT5 only)	<b>D</b> - Diffuse <b>DO</b> - Diffuse w/overlay <b>WO</b> - White Radial Louver w/overlay <b>PMW</b> - Round Perf. w/white overlay <b>SMW</b> - Slotted (Linear) Perf. w/white overlay	1/1 - One 1-Lamp ballast 1/2 - One 2-Lamp ballast	<b>CM</b> - Canadian Market <b>CC</b> - Custom Color <b>E1*</b> - DEB-1 emerg. ballast, T8 lamps, 350-450 lumens. <b>E7*</b> - DEB-7 emerg. ballast, T8 lamps, 600-700 lumens. <b>E5*</b> - DEB-5 emerg. ballast, T8 lamps 1100-1400 lumens. <b>E7LP*</b> - DEB-7LP emerg. ballast T5/T5HO, 430-700 lumens. <b>E6*</b> - DEB-6LP emerg. ballast, T5/T5HO lamps, 750-1325 lumens. <b>GLR#</b> - Fusing, fast blow (# = number of ballasts) <b>LPT730</b> - Installed T8 lamps, 70+ CRI, 3000K <b>LPT735</b> - Installed T8 lamps, 70+ CRI, 3500K <b>LPT741</b> - Installed T8 lamps, 70+ CRI, 4100K <b>LPT830HL</b> - Installed T8 hi lumen lamps, 80+ CRI, 3000K <b>LPT835HL</b> - Installed T8 hi lumen lamps, 80+ CRI, 3500K <b>LPT841HL</b> - Installed T8 hi lumen lamps, 80+ CRI, 4100K <b>LPT830</b> - Installed T8/T5/T5HO lamps, 80+ CRI, 3000K <b>LPT835</b> - Installed T8/T5/T5HO lamps, 80+ CRI, 3500K <b>LPT841</b> - Installed T8/T5/T5HO lamps, 80+ CRI, 4100K			
			<b>LAMP TYPE/WATTAGE</b>	<b>VOLTAGE</b>	<b>BALLAST TYPE</b>				
			28 - 28wT5 (46") 32 - 32wT8 (48") 54HO - 54wT5HO (46")	120 277 UNV - Universal Voltage, 120-277 volt	<b>EBD</b> - T5/T5HO/T8 electronic dimming ballast <b>EB</b> - T5/T5HO/T8 electronic ballast, std. ballast factor <b>EBL</b> - T8 Electronic ballast, low ballast factor <b>EBH</b> - T8 Electronic ballast, hi ballast factor <b>EB10I</b> - T8 Electronic ballast, <10% THD, instant start <b>EB10R</b> - T8 Electronic ballast, <10% THD, rapid start <b>EBSD</b> - T8 Electronic step dimming ballast <b>EB95</b> - 28wT5 Electronic ballast, .95 ballast factor (2 lamp only) <b>EB115</b> - 28wT5 Electronic ballast, 1.15 ballast factor (2 lamp only) <b>EBSD95</b> - 28wT5 Electronic step dimming ballast, .95 ballast factor (2 lamp only) <b>EBSD115</b> - 28wT5 Electronic step dimming ballast, 1.15 ballast factor (1 or 2 lamp)				

\*Factory installed

**JOB INFORMATION**

**0145-AR**

## ENERGY DATA

Lamp Type	Ballast Type	Input Power (120/277V)	Electrical System Lumens/Watt	
			Std. Lamps*	Hi-lumen Lamps
1 Lamp 28	EB	33W / 33W	91	–
	EBSD115@hi (@lo)	38W / 38W (19W / 19W)	88 (66)	–
1 Lamp 32	EB	31W / 31W	79	88
	EB10I	31W / 31W	79	88
	EB10R	31W / 30W	79	88
	EBL	29W / 29W	86	<b>95</b>
	EBH	41W / 41W	82	91
	EBSD@hi (@lo)	29W / 29W (14W / 14W)	85 (60)	94 (66)
1 Lamp 54HO	EB	63W / 62W	82	–
2 Lamp 28	EB95	60W / 58W	95	–
	EBSD95@hi (@lo)	60W / 58W (28W / 28W)	95 (73)	–
	EB115	72W / 71W	94	–
	EBSD115@hi (@lo)	72W / 71W (35W / 35W)	94 (80)	–
	EB	66W / 64W	95	–

## DIMENSIONS

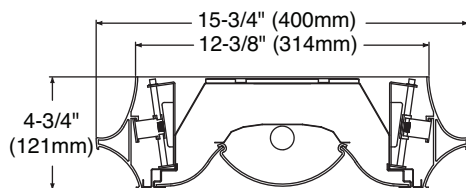

\*Standard lamp T8 values assume 70+CRI 32W lamp. 80+CRI lamps or energy saving lamps are also available.

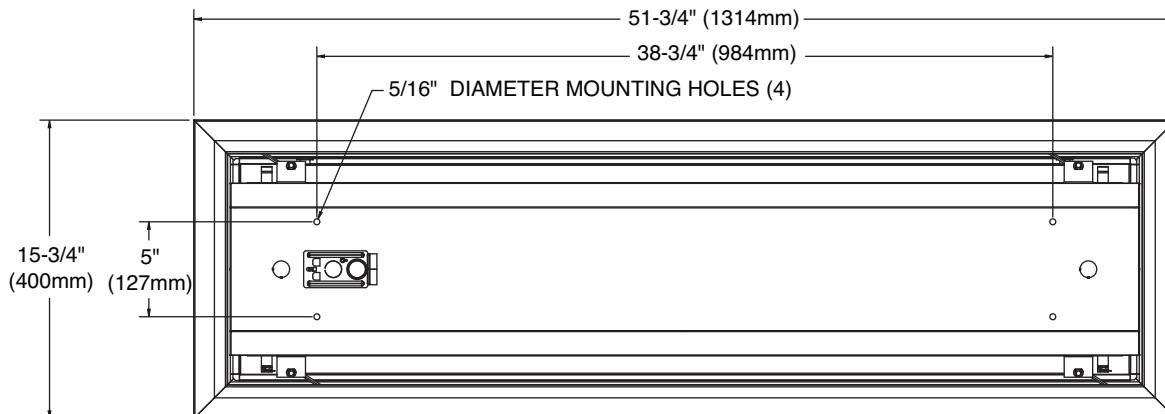

**PHOTOMETRIC DATA**

CATALOG # 1SATW128-D-1/1-EB  
TEST #25779 S/MH=1.6

LAMPS = F28T5  
BALLAST = ELECTRONIC

INPUT WATTS = 33  
BALLAST FACTOR = 1.00

LER = 65

COMPARATIVE YEARLY LIGHTING ENERGY COST PER 1000 LUMENS = \$3.69 BASED ON 3000 HRS. AND \$.08 PER KWH.

FIXTURE EFFICIENCY= 81.9%

1 LAMP T5, DIFFUSE

CANDLEPOWER				
Angle	End	45	Cross	
0	666	666	666	
5	666	668	675	
10	657	675	694	
15	643	682	721	
20	624	688	743	
25	591	678	744	
30	564	674	744	
35	527	650	715	
40	483	612	667	
45	433	561	597	
50	381	499	514	
55	323	429	429	
60	267	348	340	
65	210	271	246	
70	157	193	157	
75	106	121	88	
80	62	63	42	
85	25	19	14	

MAINTAINED ILLUMINATION TABLE- Square Feet/Fixture*			
<ul style="list-style-type: none"> <li>80-50-20 Reflectances (Ceiling-Wall-Floor)</li> <li>LLF = 0.89 2600 Lumens/Lamp very clean</li> <li>Room width divided by room height = 5 or more, 2 or 1</li> </ul>			
Fixture Size & # of Lamps	Room Width Room Height =	Approx. Area (sq. ft.) per Fixture	
		30 ft-c	50 ft-c
1x4	5	66	40
T5	2	45	-
Diffuse	1	33	-

\*Observe Fixture S/MH Requirements for Specific Applications

.89LLF = .94LDD x .95LLD x 1.0BF

COEFFICIENT OF UTILIZATION						
pfc pcc pw RCR	20		70		50	
	70	50	30	70	50	30
0	97	97	97	94	94	94
1	89	85	81	86	83	81
2	81	75	68	79	72	68
3	73	66	58	71	64	57
4	68	57	51	66	56	50
5	61	52	45	60	51	44
6	57	46	39	56	46	39
7	53	41	34	52	41	34
8	50	38	30	47	38	30
9	46	34	28	45	34	28
10	42	32	26	41	32	26

LIGHT DISTRIBUTION			
DEGREES	LUMENS	% LAMP	% FIXTURE
0-30	569	21.9	26.7
0-40	965	37.1	45.3
0-60	1737	66.8	81.6
0-90	2130	81.9	100.0

**PHOTOMETRIC DATA**

CATALOG # 1SATW132-D-1/1-EB  
TEST #25778 S/MH=1.5

LAMPS = F32T8  
BALLAST = ELECTRONIC

INPUT WATTS = 30  
BALLAST FACTOR = 0.88

LER = 59

COMPARATIVE YEARLY LIGHTING ENERGY COST PER 1000 LUMENS = \$4.07 BASED ON 3000 HRS. AND \$.08 PER KWH.

FIXTURE EFFICIENCY= 70.9%

1 LAMP T8, DIFFUSE

CANDLEPOWER				
Angle	End	45	Cross	
0	670	670	670	
5	666	670	670	
10	657	666	673	
15	643	662	678	
20	621	652	679	
25	598	634	680	
30	558	620	672	
35	519	597	660	
40	475	568	629	
45	423	527	582	
50	371	480	509	
55	314	417	413	
60	261	341	309	
65	201	255	209	
70	152	177	132	
75	103	109	78	
80	60	54	38	
85	25	18	13	

MAINTAINED ILLUMINATION TABLE- Square Feet/Fixture*			
<ul style="list-style-type: none"> <li>80-50-20 Reflectances (Ceiling-Wall-Floor)</li> <li>LLF = 0.75 2850 Lumens/Lamp very clean</li> <li>Room width divided by room height = 5 or more, 2 or 1</li> </ul>			
Fixture Size & # of Lamps	Room Width Room Height =	Approx. Area (sq. ft.) per Fixture	
		30 ft-c	50 ft-c
1x4	5	53	32
T8	2	36	-
Diffuse	1	-	-

\*Observe Fixture S/MH Requirements for Specific Applications

.75LLF = .94LDD x .91LLD x .88BF

COEFFICIENT OF UTILIZATION						
pfc pcc pw RCR	20		70		50	
	70	50	30	70	50	30
0	83	83	83	81	81	81
1	77	73	70	76	72	69
2	70	65	59	68	64	58
3	64	56	51	63	56	51
4	58	50	44	56	50	44
5	54	45	39	53	44	38
6	50	40	34	48	40	33
7	46	36	29	45	35	29
8	42	33	27	41	33	27
9	40	30	25	39	29	25
10	38	28	23	36	28	22

LIGHT DISTRIBUTION			
DEGREES	LUMENS	% LAMP	% FIXTURE
0-30	544	19.1	26.9
0-40	914	32.1	45.2
0-60	1657	58.1	82.0
0-90	2020	70.9	100.0

**PHOTOMETRIC DATA**

CATALOG # 1SATW228-D-1/2-EB95  
TEST #26627 S/MH=1.6

LAMPS = F28T5  
BALLAST = ELECTRONIC

INPUT WATTS = 58  
BALLAST FACTOR = 0.95

LER = 70

COMPARATIVE YEARLY LIGHTING ENERGY COST PER 1000 LUMENS = \$3.43 BASED ON 3000 HRS. AND \$.08 PER KWH.

FIXTURE EFFICIENCY= 82.7%

2 LAMP T5, DIFFUSE

CANDLEPOWER				
Angle	End	45	Cross	
0	1263	1263	1263	
5	1270	1263	1285	
10	1255	1279	1332	
15	1230	1300	1389	
20	1194	1317	1440	
25	1150	1323	1469	
30	1094	1310	1461	
35	1025	1274	1416	
40	944	1211	1335	
45	853	1125	1228	
50	752	1020	1099	
55	645	885	939	
60	533	744	759	
65	422	584	566	
70	313	422	375	
75	213	268	205	
80	124	131	91	
85	50	38	25	

MAINTAINED ILLUMINATION TABLE- Square Feet/Fixture*			
<ul style="list-style-type: none"> <li>80-50-20 Reflectances (Ceiling-Wall-Floor)</li> <li>LLF = 0.85 2600 Lumens/Lamp very clean</li> <li>Room width divided by room height = 5 or more, 2 or 1</li> </ul>			
Fixture Size & # of Lamps	Room Width Room Height =	Approx. Area (sq. ft.) per Fixture	
		30 ft-c	50 ft-c
1x4	5	127	76
T5	2	85	51
Diffuse	1	62	37

\*Observe Fixture S/MH Requirements for Specific Applications

.85LLF = .94LDD x .95LLD x .95BF

COEFFICIENT OF UTILIZATION						
pfc pcc pw RCR	20		70		50	
	70	50	30	70	50	30
0	97	97	97	95	95	95
1	90	85	82	88	83	81
2	81	75	69	80	73	68
3	75	66	58	71	64	57
4	68	57	51	66	56	50
5	61	52	44	60	51	44
6	57	46	39	56	46	39
7	53	41	34	52	40	34
8	48	38	30	47	38	30
9	46	34	28	45	34	28
10	42	32	25	41	32	25

LIGHT DISTRIBUTION			
DEGREES	LUMENS	% LAMP	% FIXTURE
0-30	1096	21.1	25.5
0-40	1874	36.0	43.6
0-60	3455	66.4	80.4
0-90	4299	82.7	100.0



The photometric results were obtained in the Day-Brite Lighting Laboratory which is NVLAP accredited by the National Institute of Standards and Technology.

